

TOWARDS EXTENDED PRICE MODELS IN XML STANDARDS FOR ELECTRONIC PRODUCT CATALOGS

Oliver Kelkar

Competence Center Electronic Business, Fraunhofer IAO, Nobelstr. 12c, 70569 Stuttgart, Germany

Email: oliver.kelkar@iao.fhg.de

Joerg Leukel, Volker Schmitz

Department of Information Systems, University of Essen, Universitaetsstr. 9, 45117 Essen, Germany

Email: joerg.leukel@uni-essen.de, volker.schmitz@uni-essen.de

Keywords: XML Standards, E-Catalog, E-Procurement, B2B, Price Model

Abstract: The extending interorganizational electronic business (business-to-business) means system to system communication between business partners without any manual interaction. This has led to the development of new standards for the exchange of electronic product catalogs (e-catalogs), which are the starting point for business-to-business trading. E-catalogs contain various information about products, essential are price information. Prices are used for buying decisions and following order transactions. While simple price models are often sufficient for the description of indirect goods (e.g. office supplies), other goods and lines of business make higher demands. In this paper we examine what price information is contained in commercial XML standards for the exchange of product catalog data. For that purpose we bring the different implicit price models of the examined catalog standards together and provide a generalized model.

not possible to represent all real world price models in an e-catalog using one of the available standards.

1. INTRODUCTION

Given the rapid growth and success of web-based procurement systems, e-catalogs gain an outstanding importance. Both in buy-side systems, the so-called e-procurement systems, and on B2B markets, e-catalogs are the foundation for buying decisions and the release of order transactions (Baron/Shaw/Bailey, 2001). E-catalogs are exchanged between companies. The catalog-supplying company delivers the catalog as an electronic document to the catalog-receiving company, which imports the catalog data into a procurement application (target system).

In catalogs the supplier transmits the product prices. The applicable catalog standards provide more or less powerful structures for the representation of prices. In other words, each catalog standard contains an implicit price model. The capacity of these models is very different; in particular no standard is complete, meaning that it is

The process of constructing a general price model for a XML catalog standard should take in mind the spectrum of pricing and pricing strategies. Therefore this paper is structured as follows: First we will describe pricing, as it is used in business-relationships and determine the requirements on our model. The second step is a closer look at the use of catalog data in e-business to obtain further requirements. The main task is the examination of price models of six commercial catalog standards. We will check how the selected standards meet the requirements. Finally we will present a price model, which integrates all relevant aspects and can serve to improve commercial standards.

2. PRICING IN MARKETING

Our basis for the construction of price models is the spectrum of pricing strategies and tactics, which can be used in business relationships between suppliers and buyers. The price of a product is not

limited to a direct quotation, which consists of the amount, currency and tax, but it is the result of a system of price components and rules. We define a price as the value agreed upon by the buyer and the supplier in an exchange; it is one of the four controllable variables of the marketing mix: product, promotion, price and place (Nagle/Holden, 1995).

The aim of many pricing strategies is to sell equal or similar products to different customers paying different prices. Differential pricing tries to gain higher profits in imperfect markets. For this to be effective the market must be divisible and the different segments must have different levels of demand. In general we can assume seven types of pricing:

- a) Individual Pricing
- b) Product Form Pricing
- c) Quantity Pricing
- d) Bundled Pricing
- e) Customer Segment Pricing
- f) Geographical Pricing
- g) Promotional Pricing

Individual Pricing says that the price is dependent on the buyer or customer. Especially the price is the result of an individual negotiation and fixed in a bilateral agreement; the price is customer-specific. To express this in an e-catalog, we need price types indicating, how to read a given price. Common price types are gross list price, net list price and net customer price. Additionally, buyer and supplier can define own price types (e.g. a net wholesale price with express delivery), hence it should be possible to use user-defined types in catalog documents.

An essential instrument for individual prices is granting discounts. A discount is a reduction of the price offered by a supplier to a buyer. In most cases a discount relates to an otherwise valid list price. Simple price models allow the declaration of only one discount. The effect is that two discounts must be transformed into one. For example:

- price \$100
- regular discount 5%: new price \$95
- special discount 10%: final price: $95 \times 0,9 = \$85.5$
- transform: $(\$100 - \$85.5) / \$100 = 14.5\%$

Offering slightly different variants of the same basic product with different prices is a case of *Product Form Pricing*. It is closely related to Product Differentiation, a strategy that attempts (through design, packaging, positioning, etc.) to make a clear distinction between products serving the same or different market segments. Product

Form Pricing means, that one or more characteristics of the basic product are varied, so that the offered product itself is varied. Hence it follows that we need complex product models to represent these variations in an e-catalog. One component of those complex product models is the price calculation, so the price model. Due to this close relationship we look at Product Form Pricing as a question of extended price models.

The dependence of a price on the quantity being ordered is subject of *Quantity Pricing*. Its central instrument is the quantity discount, which is often defined through a quantity scale. A quantity scale defines for each non-overlapping quantity interval a product price, which is decreasing with higher quantity. The economic reasons are decreasing marginal costs for the supplier and at the same time decreasing marginal utility for the buyer. We can distinguish two types of quantity scales: is the relevant price applied to the whole order quantity or do we apply a different price for each reached interval; e.g. the first twenty pieces: \$5, the next twenty \$4,50.

Bundling is a technique used by suppliers that consists of packaging goods or services and selling them as a single package. The price of the package is less than the sum of the included product prices. The effect of *Bundled Pricing* can be very different: either a set of rules and related discounts determines the price or the price is independent from the single prices.

A close relation exists between Individual Pricing and *Customer Segment Pricing*. Latter sets the price in dependence on the membership of the buyer to a specific segment of customers (e.g. industry, wholesale trade, retail trade, consumers). The price is not individual and not fixed in a bilateral agreement.

Geographical Pricing varies the price dependent on the place of delivery. Though this does not include costs for transportation and shipping, but it refers to other, geographic specific aspects, which often deal with separated, national markets. Coming back to e-catalogs, we should be able to determine prices for one or a set of territories (e.g. countries). Close to this determination is a respective currency tag.

A firm can set different prices for limited periods with the instrument of *Promotional Pricing*. Special promotional efforts are one reason for this. Seasonal issues, which lead to alternating prices over time (e.g. raw materials) or restricted availability of

products (e.g. collections of clothing), are another reason. The conclusion for e-catalogs is that it must be possible to express none-overlapping periods of validity and specify the type or promotional reason for the period.

3. PRODUCT CATALOGS IN E-PROCUREMENT

The theoretical concepts of pricing must be adjusted to the specific requirements of electronic procurement and enriched with further aspects. For that purpose we will point out some characteristics of e-procurement in B2B.

The main motivation of e-procurement is the reduction of process costs through speeding up and reorganizing procurement process on the basis of a convenient and fast data exchange. This leads to the extension of markets to a global level and enables in short time the interaction between large numbers of market participants with low entry costs (Gebauer/Beam/Segev, 1997). Electronic B2B communication needs, beside a technical infrastructure, a common language or at least accepted standards on the level of business data and documents.

Current examinations see many problems and obstacles for the lasting success of e-business solutions, especially of market places. Catalog management is considered as one critical success factor (Aberdeen Group, 2001). It comprehends all tasks of creating, handling and exchanging electronic catalog data. Many companies are still not able to deliver e-catalogs in appropriate form and quality.

Both in buyer-side systems (e-procurement systems), and on B2B markets, e-catalogs are the foundation for buying decisions and the release of order transactions. They serve as marketing instruments for the presentation of products as well as substitutes for offers, and must meet the requirements of professional buyers as well as ordinary employees. Next we will outline the application fields of e-catalogs in different business models.

Public web shops are the first type of B2B applications. They offer non-personalized product information and list prices. The access is not restricted. In addition, customer web shops offer customer-specific prices and sometimes customer-specific products. The access is limited and personalized. The use of multiple currencies and country-specific product variants and availability is necessary if the customers come from different countries.

The intermediary between suppliers and buyers in a marketplace builds customer-specific catalogs (or views on catalogs) and manages a multi-vendor master catalog (Ginsburg/Gebauer/Segev, 1999). Open accessible markets often demand supplier catalogs with graduated prices, multi-language product descriptions, country-specific currencies and even country-specific products. Closed markets moreover demand customer-specific prices, product assortments and products.

Table 1 shows the mentioned business models and their requirements as they relate to prices and products.

	multi-language	multi-territory	multi-prices	event-prices	customer prices	customer products	territory products	customer features	customer assortments
public web shop (sell-side)	+	+	-	+	+	-	+	-	-
customer web shop (sell-side)	+	+	++	+	++	++	+	++	++
public marketplace (intermediary)	+	+	-	+	++	-	+	-	-
customer marketplace (intermediary)	++	++	++	+	++	++	++	++	++
e-procurement system (buy-side)	+	+	-	+	++	++	++	++	++

++ = common requirement, + = possible requirement, - = no requirement

Table 1: Requirements of Business Models

The provision of catalog data for the named requirements and application needs a uniformed or standardized model. The use of catalog data makes high demands on the model relating to universal validity, flexibility and clearness (van Blommestein/Boekhoudt, 2001).

Catalog-oriented e-procurement has its roots in direct purchasing systems, these are Intranet applications which allow any employee to order needed goods of indirect demand without the participation of a purchasing department (Granada Research, 1999). Many catalog standards are tailored to indirect goods, which are not the subject of production processes. Thus the representation of direct goods and complex products is not possible. Particularly the standard price models are not sufficient to model all pricing strategies and tactics of suppliers. For example: product variants, dynamic prices and multi-staged discount systems.

The stated situation is one reason why direct or complex products are seldom integrated in e-procurement systems or catalog-oriented markets. Subsequently we notice that software companies and market places develop their own systems and modify or expand catalog standards to solve the problems. This must be seen critically as new proprietary systems are created.

Besides meta information (e.g. provider, recipient, format), a catalog document contains two areas of data: master data and transaction data. The master data consists of information about the products and this information does not change over time (or very seldom), therefore it has to be updated not very often (e.g. product number, classification, features). In contrast to this, transaction data shows a higher updating frequency. Prices, availability and delivery times are transaction data.

For the exchange of catalog data some commercial standards offer transaction types:

- complete catalog (master and transaction data)
- update of one or more products (master and transaction data)
- update of the prices of one or more products (transaction data)

The update of transaction data can be done in an asynchronous or synchronous way. For example, an electronic price list is an asynchronous update transaction, while an online query for prices or availabilities is a synchronous transaction.

4. PRICE MODELS IN XML CATALOG STANDARDS

Being aware of the pricing instruments and the general conditions of catalog-based e-procurement now we can analyze existing price models in commercial XML standards. Object of the analysis are *structures* representing price information. This is a main difference to the marketing view on pricing, which emphasizes the *economic reasons and motivations* for a specific price instrument (Klein/Loebbecke, 1999).

Starting points for answering the question, which price information is modeled in catalog standards, are the specifications, documentations and (if available) the data models. The analysis covered 20 XML standards in all. Due to limited space we will concentrate on six selected standards. The selection contains the most important standards being used in B2B e-commerce:

- cXML and xCBL: two standards developed by major e-business software companies (Ariba, 2001; CommerceOne, 2001)
- BMEcat: successful standard in Germany and Europe (Schmitz/Kelkar/Pastors, 2001)
- EAN.UCC: standard by EAN (EAN International, 2001)
- OAGIS: documents will be integrated into ebXML (Open Applications Group, 2001)
- RosettaNet: horizontal standard (RosettaNet, 2001)

Table 2 shows basic information about the selected standards.

The result of our empirical analysis is a general price model, which will be presented as an XML Schema (W3C, 2001). During the following description of the price model and its components we state the names of the relevant data elements in angular brackets, e.g. (*Price*) as the root element.

4.1 Structure of Price Models

In Section 2 we have described the instruments of pricing, though we can not assume that neither these instruments are fully integrated in product catalogs nor that they are represented in an one-to-one relation. Rather catalog standards introduce a couple of concepts that are necessary to reduce the complexity of a price model:

- (1) Concept of Levels: Assuming that a price model consists of components, which together

Standard	cXML	xCBL	BMEcat	EAN.UCC	OAGIS	RosettaNet
Version	1.2.007	3.5	1.2	1.0	7.2.1	1.0
	November 2001	November 2001	March 2001	July 2001	November 2001	June 2000
Organization	Ariba, Inc.	CommerceOne, Inc.	eBSC	EAN	Open Applications Group	RosettaNet
Line of Business	independent	independent	independent	independent	independent	IT & Electronic Components
Origin	USA	USA	Germany	International	International	International
URL	www.cxml.org	www.xcbl.org	www.bmecat.org	www.uc-council.org	www.openapplications.org	www.rosettanelt.net

Table 2: Selected XML Catalog Standards

describe the product price, we can identify three business levels for price components: Product, Transaction, Contract.

Product catalogs represent the level Product, all price components are assigned to products of the catalog. In contrast to this, the components on the level Transaction describe factors, which are determined by the order transaction, e.g. costs for packing and transportation of all products of one specific order. The level Contract comprises definitions, which are fixed in a bilateral agreement. A contract aggregates timely or functionally related transactions. For example, at the end of a period the supplier gives an allowance on a previously defined order volume. In most cases product catalogs reference to one or more contracts; the contract itself is not specified through a contract model.

(2) Concept of Dependence: The price of a product is dependent on many factors (e.g. customer, territory). To describe a price we must set the values of these determining factors, so we determine the validity of the price. The set of factors leads to an even model.

(3) Concept of Allowances and Charges: All components of a price model, which result in a reduction or addition to a basic price, can be united to a model of allowances and charges. By way of explanation it is sufficient to specify the type or reason for the allowance or charge.

4.2 Product Prices and their Determining Factors

The real product price is dependent on many factors: order unit, place of delivery, customer, price type, contract, (time) interval and currency. Each of these factors is independent from the others and can be used without any overlapping to specify an actual price. The theoretically number of prices for one product is calculable through the combination of

values of all factors. Many catalog standards make restrictions by allowing only one value per definition (e.g. all prices are net list prices), or the supplier must set default-values for all products of the catalog document (e.g. the currency of all prices is Euro). The complexity of a price model is reduced through these two measures.

Afterwards we explain relevant factors:

(1) Order Unit: The most evident factor of a price is the order quantity and order unit. Though equal basic products with different order units can be seen as separate products also.

(2) Territory: Prices are due to Geographical Pricing often dependent on the place of delivery. Therefore, a supplier is able to set different prices for each territory. Often logistic costs, taxes and duties are included, so these price components must not be declared explicit. (*DeliveryRegion*)

(3) Customer: Individual Pricing is characteristic for B2B relations; it leads to customer-specific prices. In multi-buyer catalogs it is necessary to transfer, besides the customer-independent core data, for each customer individual prices. (*Customer*)

(4) Price Type: Price types serve to express short and clear statements about the price. In many cases, the trade level of the buyer and the handling of turnover taxes are stated (gross or net prices). Information about special promotions (restricted by time and/or region) is also a matter of price types. As far as that goes price types are a component for implementing Individual, Geographical and Promotional Pricing. (*PriceType*)

(5) Interval: In general prices are valid for a limited period of time. Hence it is evident to differentiate prices to their interval of validity (Promotional Pricing). If no interval is transferred in an e-catalog, then the price is valid until a new price is transferred. (*ValidityTimePeriod*)

(6) Contract: A skeleton or project agreement defines often all price components, which can be fixed in advance. In this case the complexity of price factors in e-catalogs is very small. The catalog supplier has to give a reference to the agreement (Individual Pricing). (*Agreements*)

(7) Currency: Each price is to be expressed in a currency. For internationally used e-catalogs it is important to assign at the same time prices in different currencies. The currency results from Geographical Pricing. (*Currency*)

For example most of the mentioned factors are implemented in the BMEcat standard (Hümpel/Schmitz, 2000). The data element ARTICLE_PRICE_DETAILS can be used multiple with disjunctive intervals. The key values for ARTICLE_PRICE are currency (PRICE_CURRENCY), lower bound of a quantity scale (LOWER_BOUND), a set of territories (TERRITORY) and the attribute price type, which is not shown in figure 1.

Besides the factors we must take in mind that the price quotation itself can show a varied complexity (*ProductPrice*). In principle we can differentiate three complexity levels:

- Price quotation through an amount and an optional multiplier, e.g. \$5 per 1,000 pieces (*SimpleAmount*)
- The price is linear dependent on one or many product features, which will be instantiated through a real order transaction, e.g. 5 piece of cable each with a length of 6 meters. (*ParametrizedAmount*)
- The price is dependent on any parameters and it will be calculated through a formula at the time of order. Examples for these parameters are market prices, delivery terms, delivery range and delivery time. (*AmountFormula*)

In a special case, the price is not expressed in the catalog document, but it must be requested from the supplier at the moment of order (*PriceRequest*).

4.3 Product Bundling

As described above Bundled Pricing means packaging goods or services and selling them as a single item. The price of the package is less than the sum of the included product prices. In e-catalog we can look at product bundles as separate products with a price being independent from the single prices. To sum it up, all types of pricing can be applied to a bundle as well. (*SetPrice*)

4.4 Allowances and Charges

Allowances and charges are a powerful instrument for pricing. Analogous to this, the complexity of necessary models must be seen: it ranges from simple multipliers to high complex relations. (*AllowOrCharge*)

The calculation of allowances and charges happens on a basis (*BaseType*), which identifies how allowances and charges (*AllowOrChargeValue*) flow into the price calculation. There are four different methods, which all are realizing both allowances and charges:

- relative, percent: the allowance or charge is multiplied with the product price using a factor (e.g. 10% discount per product, factor is 0.9) (*PercentageFactor*)
- relative, amount: the allowance or charge is added to the product price with a fixed value (e.g. \$10 for shipping). (*MonetaryAmount*)
- absolute: the product price is replaced by the allowance or charge. This can be combined with rules. Minimum or maximum rules are often used,

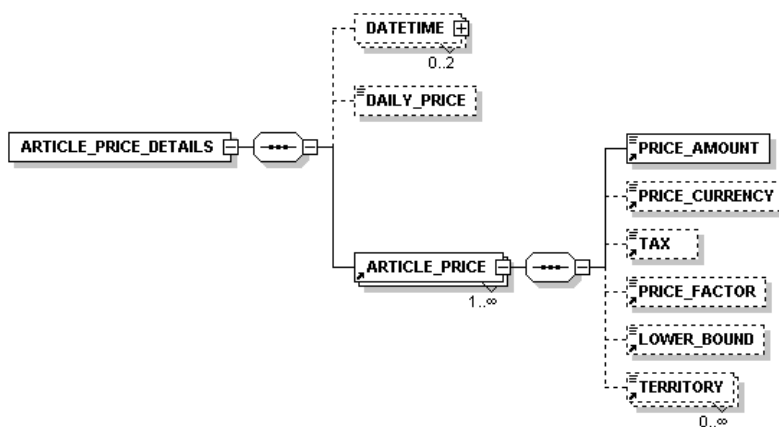

Figure 1: Price Factors in XML Standard BMEcat

e.g. use the lower amount of the product price and the allowance. (*MonetaryAmount*)

- natural: the number of delivered products is higher than the number ordered, but only the ordered products are charged (e.g. rebate in kind). (*AdditionalOrderUnits*)

To reveal why an allowance or charge is applied, we need a characterization (*AllowOrChargeType*) optionally combined with a description (*AllowOrChargeDescription*). The first aspect is whether it is a volume-based or a functional allowance (or charge). In case of the volume-based kind, the allowance begins to take effect if a certain volume limit is crossed (*PriceBracket*). These volume limits are either quantitative (e.g. quantity scale, (*UpperBoundAmount*)) or in terms of value (e.g. allowance at the end of a settlement period, (*UpperBoundQuantity*)). Both allowances are instruments of Quantity Pricing. The functional allowances relate to performance-oriented criterions, these criterions are described through textual remarks or special codes (e.g. packaging flat rates, duties or cash discounts (Product Form Pricing).

The relative amount allowances can be modeled in another way: often separate products are inserted instead of charges. These products describe the charge and appear as additional positions in the invoice. To use this alternative in e-catalogs, we need relations between products, which are similar to configurable products. Though product configuration is a not subject of this paper.

The kind of calculation of allowances and charges determines how and when the amount is credited to the buyer (*SettlementType*). This is according to the Concept of Levels. An allowance can be credited for all products of a transaction or at the end of a contract period.

The order of calculation of allowances and charges plays an important part (*SequenceNumber*). A multistage system of discounts needs a defined order of calculation. On each stage of this system two or more discounts “of equal rights” can exist at the same time. In this case, the discounts have to be added before they can be applied.

Another question is how to document the allowances in an e-catalog. An answer is to give the final price and name the applied discounts (e.g. \$95 including 5% senior discount). The alternative is to name the list price and all discounts without giving the final price (e.g. \$100, 5% discount, 8% special discount, plus 16% tax).

4.5 Taxes

Taxes are a special form of charges, which must be - due to their legal importance - expressed separately. According to country and line of business it is necessary to describe more than one tax. (*Tax*)

	Territory	Customer	Price Types	Interval	Contract	Currency
cXML	-	-	-	-	-	-
xCBL	-	+	+	+	-	+
BMEcat	+	-	+	+	-	+
EAN UCC	-	-	-	+	-	-
OAGIS	-	+	+	-	-	-
RosettaNet	-	-	-	-	-	-

Table 3: Determining Parameters in XML Catalog Standards

	Basis				Cal- cula- tion Order	Types	Scale		Kind of Calculation
	relative, percent	relative, amount	absolute	natu- ral			Quantity	Value	
cXML	-	-	-	-	-	-	-	-	-
xCBL	-	-	-	-	-	-	-	-	-
BMEcat	+	-	-	-	-	-	+	-	-
EAN UCC	+	+	+	-	+	+	+	+	+
OAGIS	-	-	-	-	-	+	+	+	-
RosettaNet	-	-	-	-	-	-	+	+	-

Table 4: Allowances and Charge in XML Catalog Standards

5. COMPARISON & SYNTHESIS OF PRICE MODELS

To compare the price models of the selected standard, we show in table 3 the six determining factors. A plus (“+”) indicates that the corresponding factor can be set multiple for each product. For example, in BMEcat the prices of a product are valid for different territories and intervals, in different types and currencies, but all prices relate to the same customer (no multi-buyer catalogs).

The model components that specify allowances and charges are summarized in table 4.

On the basis of the model components, which were identified from the standards and structured above, we can develop a general model. The model in figure 2 uses the data element names that we have introduced before. To keep clearness, some simplifications are made. For example, elements that can appear more than once are not represented with an own container (“ListOf...”).

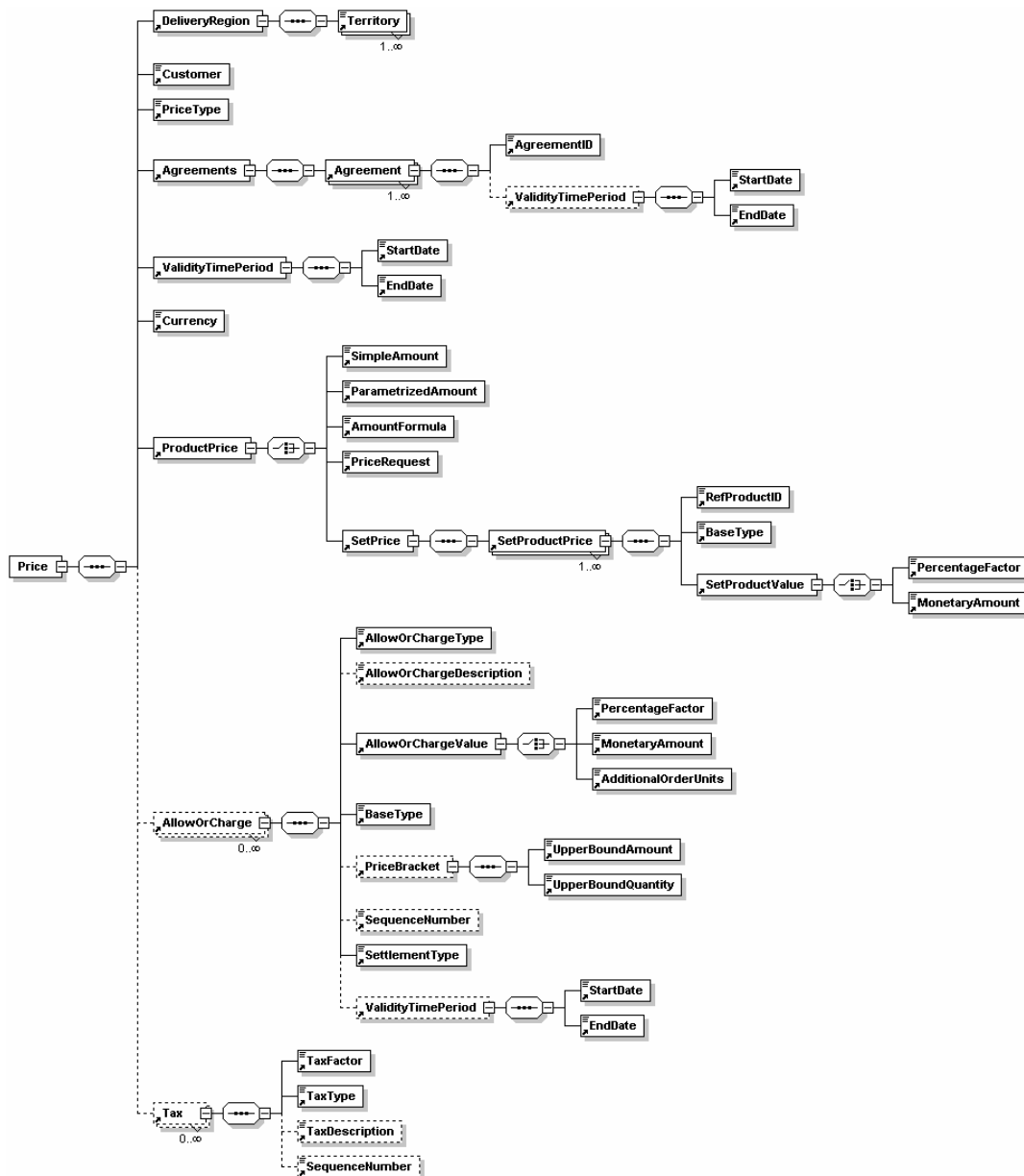

Figure 2: Derived Price Model

The model shows only the level of product prices. It is possible to model the levels Contract and Transaction quite similar.

Further we have simplified the issues of price formulas (not handled in detail in this paper) and product bundling. All determining factors are modeled as mandatory elements; the reason is their meaning as key values. As explained in Section 3, an alternative would be to set default values for some or all factors in the catalog header. In this case, the data elements for factors are optional.

6. CONCLUSION

In this paper we have discussed the problem of modeling price information in e-catalogs and suggested a general price model for XML catalog standards, which is the result of a theoretical (pricing strategy) and empirical analysis (commercial standards).

We found out that the spectrum of real world price models is covered in a limited way by available standards. Speaking of the suppliers and buyers, it is necessary to represent more complex price models in catalog documents. For example, the industrial trade uses multi-staged discount systems along the trade levels. As long as this is not covered, we see a major obstacle for the fast success of e-business applications. On the other hand it is necessary to reduce the complexity of price models to be able to develop, deploy and handle a generalized model.

The developed model is the result of an empirical analysis catalog standards published at the time of the survey. As a general model it is in a position to represent all issues that are modeled by the available standards. The question of its general validity cannot be answered finally, since it is possible that in practice or theory price-relevant circumstances exist, which were considered so far by no standard. However, two modeling concepts increase the scope of validity considerably: On the one hand the Concept of Dependence and on the other hand the Concept of Allowances and Charges. If additional price determining factors are needed, then the Concept of Dependence can be extended by these easily. Besides price modeling, the representation of complex goods is another unsolved problem. This underlines our conviction that further research and standardization must be done to come to universal and accepted business documents.

REFERENCES

- Aberdeen Group, 2001. *Content Integration: e-Catalog Aggregation for Buyers and Asset Control for Suppliers*, An Executive White Paper, Boston.
- Ariba, 2001: *cXML*, Version 1.2.007. Online: <http://xml.cxml.org/current/cXML.zip>.
- Baron, J. P. / Shaw, M. J. / Bailey, A. D., 2000. Web-based E-catalog systems in B2B Procurement. In *Communications of the ACM (CACM)*, Vol. 43 (2000), No. 5, p. 93-100.
- CommerceOne, 2001: *XML Common Business Library (xCBL)*, version 3.5. Online: <http://www.xcbl.org/xcbl35/xcbl35.html>.
- van Blommestein, F. / Boekhoudt, P., 2001. *Electronic Procurement of Technical Materials*, Project Report, Telematica Instituut, Netherlands.
- EAN International, 2001: *EAN.UCC Business Message Standards*, Version 1.0, 2001. Online: <http://www.ucc-council.org>.
- Gebauer, J. / Beam, C. / Segev, A., 1997. *Impact of the Internet on Procurement*, Research Report 97-WP-1024, Haas School of Business, University of Berkeley.
- Ginsburg, M. / Gebauer, J. / Segev, A., 1999. Multi-Vendor Electronic Catalogs to Support Procurement: Current Practice and Future Directions. In *12th International Bled Electronic Commerce Conference*, Bled, Slovenia.
- Granada Research, 1999. *E-Catalog 99: Business-To-Business Electronic Catalog*, Technology Report, El Granada.
- Hümpel, C. / Schmitz, V., 2001: BMEcat - an XML standard for electronic product data interchange. In: *Proceeding of the 1st German Conference XML 2000*, Heidelberg, Germany, p. 1-11.
- Klein, S. / Loebbecke, C.: Signaling and Segmentation on Electronic Markets: Innovative Pricing Strategies for Improved Resource Allocation. In: *Proceedings of the 6th Research Symposium on Emerging Electronic Markets*, Muenster, Germany, p. 127-142.
- Nagle, T. T. / Holden, R. K., 1995. *The Strategy and Tactics of Pricing: A Guide to Profitable Decision Making*, Prentice Hall, 2nd Edition.
- Open Applications Group, 2001: *Open Applications Group Integration Specification*, Release 7.2.1. Online: <http://www.openapplications.org>.
- RosettaNet, 2001: *PIP2A1: Distribute New Product Information*, Release 1.0. Online: <http://www.rosettanet.org>.
- Schmitz, V. / Kelkar, O. / Pastoors, T., 2001: *Specification BMEcat*, Version 1.2. Online: <http://www.bmecat.org>.